

CITYBAC®

500L



SULO®

Citybac® 500L

PRODUCT DETAILS



- 1 Flat Lid
- 2 Handle / handle recess
- 3 Handles with handle bar, rear 2x
- 4 Marking areas

- A Body
- B DIN comb lifting system, double stage
- C Marking areas
- D Chip nest as standard
- E Functional castors 2x
- F Swivel castors 2x



MANUAL LOCK

AUTOMATIC LOCK

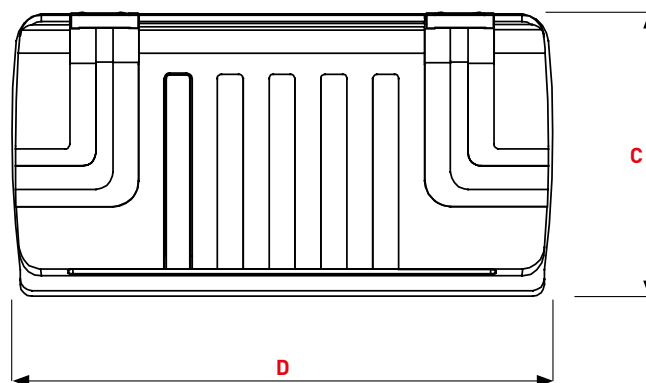
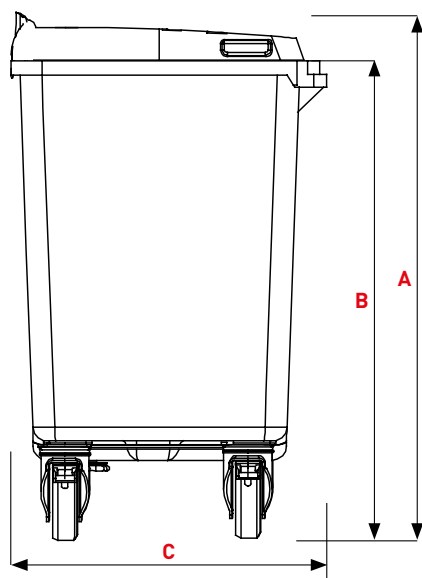

STANDARD LID

Dimensions (mm)

A Height total ~	1097
B Comb height ~	997
C Bin depth ~	667
D Width total ~	1210

Weights

Volume nominal (L)	500
Empty weight (kg) ~ EN 840 Norm	34
Max. filling weight (kg) ~	200

Citybac® 500L

PRODUCT DETAILS

COLOURING



ANTHRACITE GREY
RAL 7021
AT
 CIRCULAR ECO
 ■■■■■■

Bin bodies made of up to 100 % post-consumption recycle. We are able to achieve an average share of 70 % domestic recycle (packaging, caps) and 30 % nondomestic (bins, industrial scrap, pallets)

100% RECYCLED MATERIAL



RAL 7021



RAL 7011



RAL 6011



RAL 6009



RAL 8025



RAL 5023

VIRGIN MATERIAL



RAL 9010



RAL 7038



RAL 5015



RAL 5005



PANTONE 5395C



RAL 3974GN



PANTONE 167 C



RAL 3000



RAL 3005



RAL 1018

ALTERNATIVE COLOURS FOR THE BIN BODY



GREEN
RAL
6011
VJ

CIRCULAR ECO
 ■■■■■■



BROWN
RAL
8025
MR

CIRCULAR ECO
 ■■■■■■



BLUE
RAL
5023
BN

CIRCULAR ECO
 ■■■■■■



RED
RAL
3000
RN

CIRCULAR ECO
 ■■■■■■



ORANGE
PANTONE
167 C
OF

CIRCULAR ECO
 ■■■■■■



YELLOW
RAL
1018
JA

CIRCULAR ECO
 ■■■■■■

Other colours and colour combinations available on request, subject to sufficient order quantities. Colours may vary due to production. The colour values given according to RAL are guide colours.

+ OPTIONS

FRACTION MARKING



Clip available in the colours



Label for Lid, individual printing possible

LID SLOT SYSTEMS

Packaging

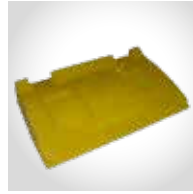

Lid-in-Lid, small Lid always in **Yellow RAL 1018**

Glass

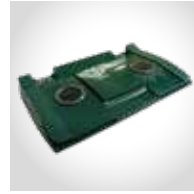

Round slot with rubber rosette Ø 150 mm, lock or bolt required

Paper

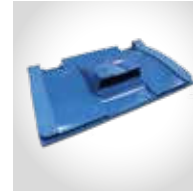

Paper hood for newspapers and magazines in **Blue RAL 5023**

NOISE REDUCTION



Lid closing damper

DRAINAGE



Drain plug

LIFTING DEVICES



Front



Swiss



Trunnions

ACCESSORIES

TRANSPORT SYSTEMS



Fixed position with handle at the back of the body



Bottom reinforcement



Towbar

CHASSIS



Ø 160 mm Wheel - Swivel castor

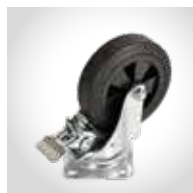

Ø 160 mm Wheel - Castor with brake



Ø 200 mm Wheel - Swivel castor

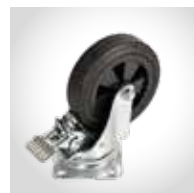

Ø 200 mm Wheel - Castor with brake



Steering lock (can be fitted to any type of castor)

LOCKING SYSTEMS



Automatic lock with triangular key



Automatic lock with individual key



Manual lock with triangular key

Citybac® 4-Wheel

TECHNICAL INFORMATION

500 LITRE

LIFTING SYSTEM	
DIN COMB	■
LID TYPE	
Standard	■
Domed	
LID SLOT SYSTEMS	
Paper hood	■
Paper hood XXL for cardboards	
Round slot with rubber rosette Ø 150 mm,	■
Lid-in-Lid,	■
Clip	■
NOISE REDUCTION	
Plots	■
Lid Opening Noise Reduction	
LOCKING SYTSEMS	
Manual lock	■
Automatic lock	■
Automatic bolt	
LIFTING DEVICES	
Front	■
Swiss	■
Trunnions	■
Trunnions with metal sleeve	
Forklift device	
Metal trunnions	
CHASSIS	
Standard castors ø 160	■
Standard castors ø 200	■
12km/h reinforced wheel ø 160	■
12km/h reinforced wheel ø 200	■
Non-marking wheels ø 160	■
Non-marking wheels ø 200	■

500 LITRE

ACCESSOIRES

Lid opening via pedal	
Fixed position with handle at the back of the body	Standard
Rim reinforcement	CEN A
Bottom reinforcement	CEN A
Towbar	CEN A

DRAIN PLUG

Drain plug	■
------------	---

ANTI-ODOUR

Anti-odour	■
------------	---

LABELLING

Photo injection on the lid	Standard
Sticker	■
Embossing insert	Standard
Hot foil stamping	■

IDENTIFICATION

RFID Chip	■
Specific numbering	■

sulo.com

DATA-CITYBAC-500L-LA-EN-1-0-201221

SULO[®]